

HAWK RACING™

Installation Manual

SRAM kit - V2

ENG 1.0

IMPORTANT NOTICE

Servicing and installing Hawk Racing products often requires advanced bicycle knowledge and specialized tools. Please visit your authorized Hawk Racing dealer or local bike shop to ensure proper installation of your Hawk Racing bottom bracket with a SRAM crank set.

With the new Hawk Racing SRAM kit - V2, it is not necessary to remove the already installed bottom bracket. Follow the instructions below to install your Hawk Racing bottom bracket with your SRAM crank set.

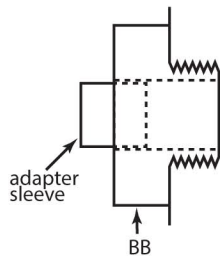

STEP ONE (1)

Insert the adapter sleeve half-way into the NonDrive side (left) dust cap.

ENG bottom bracket cup is shown, but it could be a PressFit bottom bracket as well.

STEP TWO (2)

Insert spring onto crank spindle.

STEP THREE (3)

Insert 0.5mm shim onto crank spindle.

STEP FOUR (4)

Insert 1.0mm shim onto crank spindle.

The amount of shim is based on a 68mm bicycle bottom bracket shell width with an ENG threaded Hawk Racing bottom bracket.

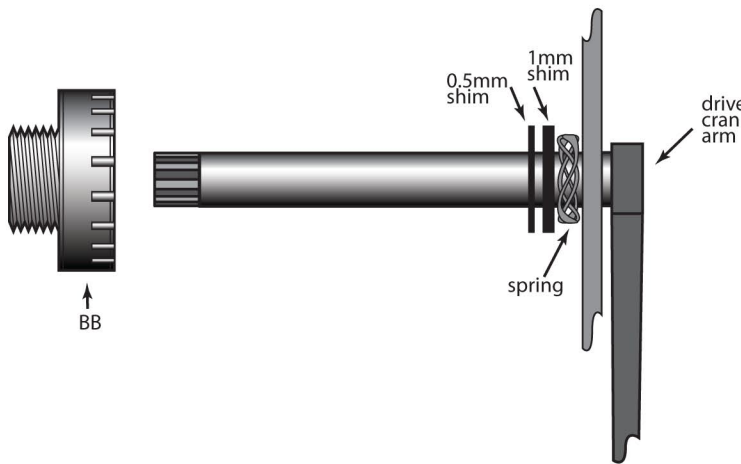

STEP FIVE (5)

Insert DriveSide crank arm into Drive-side bottom bracket cup. Grease crank spindle slightly with lubricant. We recommend White Lighting crystal clear grease available at our online store.

STEP SIX (6)

Ensure that the NonDrive-side crank arm is not pushing out the adapter sleeve already installed.

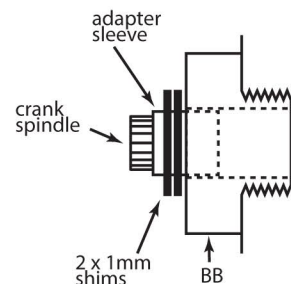

STEP SEVEN (7)

Install 2x1mm shims on the NonDrive-side of the bottom bracket, making sure that they rest on the adapter sleeve, and not on the crank spindle.

STEP EIGHT (8)

Install the NonDrive-side crank arm and torque down to SRAM's specifications.

NOTE: If the crank set is not spinning smooth after the correct amount of torque has been applied, a shim may need to be removed.

Ensure your crank set has no left and right play. Furthermore, after riding approximately 100 km (60 miles), use a torque wrench to re-check the tightening torques. Improper installation may cause injury to the rider.

All trademarks cited in this guide are the property of their respective owners.